



Séries
NSX

SIZE 5 SOCKET COAX CONTACT
FOR RAYCHEM 5012K1011 CABLE
BOEING P/N: BACC47EU-2

Issue:
09 FEB. 94

Page
1 / 1

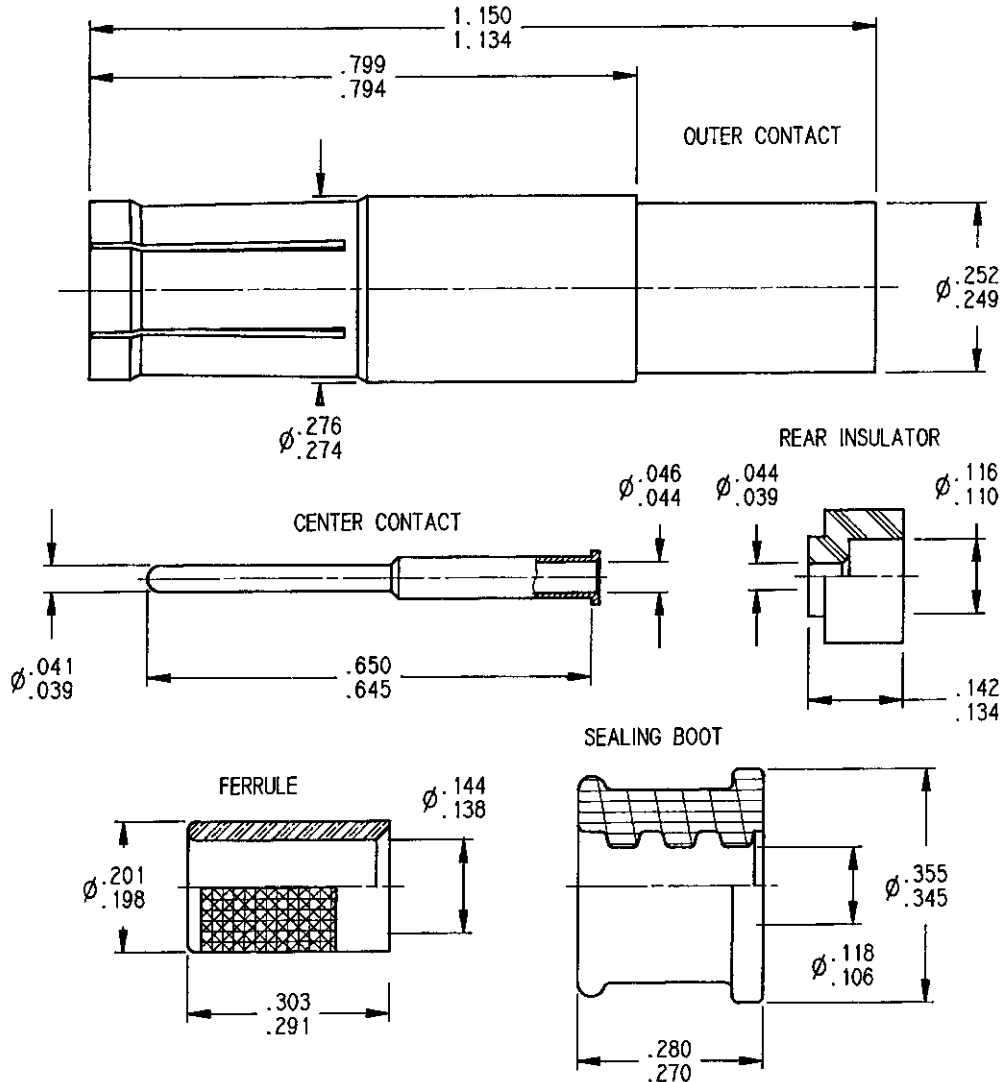

MATERIAL:
 OUTER CONTACT: BERYLLIUM COPPER HEAT TREATED FOR SPRING TINES
 INSULATOR: TPFE
 CENTER CONTACT: BRASS PER QQ-B 626
 FERRULE: BRASS
 SEALING BOOT: SILICONE ELASTOMER
FINISH (ALL METAL PARTS)
 GOLD PLATE PER MIL_G_45204: 50 MICROINCHES OVER NICKEL

DESIGN REQUIREMENTS
 TEMPERATURE RANGE: -65°C TO +165°C
 IMPEDANCE: 50 OHMS NOMINAL
 RATED VOLTAGE: 325 V RMS AT SEA LEVEL
 VSWR: 1.30:1
 FREQUENCY RANGE: 0 - 500 MHZ
 CONTACT RESISTANCE: 1.0 MILLIOHMS MAX (OUTER CONTACT)
 DIELECTRIC WITHSTANDING VOLTAGE: 750 VRMS AT SEA LEVEL

CONTACT SHALL ASSEMBLE USING TOOLING AND STRIP LENGTHS ACCORDING TO RP08710

This information is given as an indication. In the continual goal to improve our products, we reserve the right to make any modifications judged necessary.

CREATION					
PEN: .					
NOM: JP MACARI					
DATE: 23 DEC. 93	09.02.94	CHANGE FERRULE SHAPE Ø.201/.198 WAS .193/.191	JP MACARI	CALEWA	
APPR: CALEWA	Issue	Revisions	Name	Approved	